

# ADDENDUM NO. 1

APRIL 17, 2017

**RE: COLVILLE AIRPORT TRANSMISSION MAIN**

**OWNER: CITY OF COLVILLE**

**FROM: Welch, Comer & Associates, Inc.**  
350 E. Kathleen Ave.  
Coeur d'Alene, Idaho 83815  
Phone: (208) 664-9382 Fax: (208) 664-5946

**TO: ALL PLAN HOLDERS**

The following modifications, clarifications and information are hereby made a part of the contract provisions and shall be fully binding.

This Addendum consists of **4** pages: 2 Addendum pages and 2 pages of attachments.

**IMPORTANT:** Bidders must acknowledge receipt of this Addendum as well as all other issued addenda on the Bid Form provided with the Contract Documents, which must be utilized by Bidder for bid to be considered responsive. Failure to do so may subject Bidder to disqualification.

## TECHNICAL SPECIFICATIONS:

With reference to **Section 00 4100, Pay Item No. 321123.02**, shall be revised to read as follows:

Pay Item No.	Description	Unit	Estimated Quantity	Unit Price	Price
321123.02	¾" Minus Aggregate	TON	<del>1575</del> 1275	\$	\$

With reference to **Section 00 4100, Pay Item No. 331116.23**, shall be revised to read as follows:

Pay Item No.	Description	Unit	Estimated Quantity	Unit Price	Price
331116.23	16-Inch AWWA C540 Butterfly Valve	TON	≥ 1	\$	\$

## DRAWINGS:

With reference to **Sheet C1**, revise as follows:

1. Station 10+00, delete reference in blow up to 12" C900 DR18.
2. Station 10+09.39, call out shall be revised to read (1) 12" MJXMJ DI 22.5 degree bend, Mechanically Restrained.
3. Station 13+41.48, delete 16" Gate Valve.

With reference to **Sheet C4, Station 23+75**, add 16" Butterfly Valve.

With reference to **Sheet C4, Hatched Area of Taxiway**, delete note "Type A3 Surface Restoration" from plan view.

With reference to **Sheet C5, Hatched Area of Taxiway**, delete notes "Type A3 Surface Restoration", and "Start Type A3 Surface Restoration" from plan view.

With reference to **Sheet C7, Tie Into Existing 16" DI PVC Waterline**, revise as follows:

1. Reference shall read: **Tie Into Existing 16" DI Waterline.**
2. Add the following note: Contractor shall Cut, Cap and Abandon existing 12" Waterline south of the tie in upon activation of new 16" water main. This work shall be considered incidental to 16" Tie in.

With reference to **Sheet DT1**, replace Detail 5 with attached revised Dual Pipe Trench Detail.

#### **CLARIFICATION:**

1. **Sheet C6**, Tie Down Pad is asphalt. If Tie Down Pad is disturbed during construction, Contractor is responsible for restoring it per the asphalt surface restoration detail: **Detail 4, Sheet DT1.**

#### **Attachments**

Dual Pipe Trench Detail

Pre-Bid Meeting Sign-in Sheet

**END OF ADDENDUM 1**

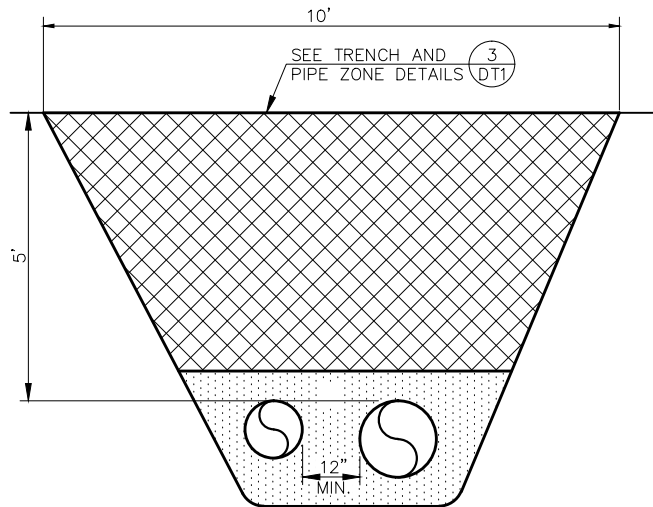

**DUAL PIPE TRENCH SECTION**

NO SCALE



www.welchcomer.com  
 350 E. Kathleen Ave.  
 Coeur d'Alene, ID 83815

208-664-9382  
 (toll free) 877-815-5672  
 (fax) 208-664-5946

COPYRIGHT 2017  
 Welch-Comer & Associates, Inc.  
 This document, and ideas and designs  
 incorporated herein, as an instrument  
 of professional service, is the property  
 of Welch-Comer & Associates, Inc.,  
 and is not to be used in whole or in  
 part for any other project without the  
 written authorization of Welch-Comer  
 & Associates, Inc.

CITY OF COLVILLE  
 COLVILLE AIRPORT TRANSMISSION MAIN

DUAL PIPE TRENCH DETAIL

PROJECT NO.: 52024  
 DESIGNED BY: N.M.M.  
 DRAWN BY: J.A.L.  
 DWG NAME: 52024DT01.DWG  
 DATE: 04-17-17  
 SHEET NO:

# 4/12/17 Pre bid Roster

## Colville Airport Transmission Main

E MAIL

Jim Tucker	welch corner	208-691-1351
Row Frostman	City	
JEFF HEETER	SADBY CONSTRUCTORS	jeff.heeter@ sadbysconstruction.com
Lyn Walker	Western Construction	Lyn@western.com
MARK PEDERSON	WM WINKLER	mpeders@wmmwinkler.com
Trevor Brown	ICA	Trevor.Brown@oldcastlematerials.com
GARY EICHLER	ICA	Trevor.Brown@oldcastlematerials.com
Walt Haucke	ACT	whaucke@acimw.com
Shem Johnson	STL Lundberg Inc	shem@stlundor.com
GARY HASTINGS	INTERSTATE	680-0080
Grego Stewart	Stewart Construction	208-682-9018
Nat Baker	Colville Construction	nat@colvilleconstruction.com